

**BREAKTHROUGH ON CO<sub>2</sub> SUPERSONIC SEPARATION TECHNOLOGY**

Dárley C. de Melo<sup>1</sup>, Wilson M. Grava<sup>2</sup>, Jailton F. Nascimento<sup>3</sup>, Bagirov Lev Arkad'evich<sup>4</sup>, Imaev Salavat Zainetdinovich<sup>5</sup>, M. Reda Akdim<sup>6</sup>, Igor R. Lourenço<sup>7</sup>

**Copyright 2014, Brazilian Petroleum, Gas and Biofuels Institute - IBP**

This Technical Paper was prepared for presentation at the *Rio Oil & Gas Expo and Conference 2014*, held between September, 15-18, 2014, in Rio de Janeiro. This Technical Paper was selected for presentation by the Technical Committee of the event according to the information contained in the final paper submitted by the author(s). The organizers are not supposed to translate or correct the submitted papers. The material as it is presented, does not necessarily represent Brazilian Petroleum, Gas and Biofuels Institute' opinion, or that of its Members or Representatives. Authors consent to the publication of this Technical Paper in the *Rio Oil & Gas Expo and Conference 2014 Proceedings*.

---

**Abstract**

The presence of high CO<sub>2</sub> contents in Pre-Salt gas fields has prompted the need to investigate new, compact and efficient technologies to remove CO<sub>2</sub> from the hydrocarbon gas in order to comply with export specifications. As gas treatment in Brazil mainly occurs offshore on Floating Production Storage Offloading (FPSO) vessels, there is a strong incentive to reduce complexity, footprint and weight of any proposed new gas treatment technology.

One of the new technologies is 3S (Super Sonic Separation) which is a compact separation device based on the principle of supersonic flow (Mach number >1), technology being developed by ENGO Engineering Ltd. in Russia. The 3S device has been proven and is currently in operation for dewpointing applications and, with respect to a new device for the removal of CO<sub>2</sub> from natural gas, some tests performed under laboratory conditions will be presented in this work.

The main goal of this study carried out by Petrobras in cooperation with FMC Technologies was to achieve the technology proof of concept regarding the 3S device for CO<sub>2</sub> separation. This analysis has been performed by investigating phase envelopes, and its separation performance was checked by laboratory tests.

**1. Introduction**

Climate change is a global issue which requires global solutions in order to reduce CO<sub>2</sub> emissions. Oil and natural gas will remain indispensable in our daily lives for many years to come. The challenge is to produce the necessary oil and gas in the most environmentally friendly manner. In the Oil and Gas Industry, CO<sub>2</sub> is also a matter for selecting special materials, leading to high cost, weight and complex manufacturing; and the carbon dioxide reduces the heating value of natural gas stream wasting pipeline capacity.

Currently, Pre-Salt carbonate reservoirs are considered the most important recent oil discovery and some fields contain a large volume of gas associated with oil. The presence of high CO<sub>2</sub> contents in gas streams is one of the many technical challenges to overcome related to the production development of the Pre-Salt area.

Moreover, in the offshore environment, the severe space restrictions of the Floating Production Storage Offloading (FPSO) have prompted many parties to investigate new technologies that could simplify the process and reduce footprint of the treatment plants (Mikkelsen and Melo, 2013). As gas production in Brazil mainly occurs offshore on FPSO vessels, there is a strong incentive to reduce complexity and footprint to allow the increase of the plant capacity and efficiency in future production units. This may also lead to savings in investment cost and operational expenditure.

Petrobras has decided not to vent the CO<sub>2</sub> produced with the associated gas in order to reduce the emissions to the atmosphere (Formigli Filho et al., 2009). To process natural gas streams with high concentrations of CO<sub>2</sub> (up to 60%

---

<sup>1</sup> MSc, Process Engineer - PETROBRAS

<sup>2</sup> DSc, Coordinator - CO<sub>2</sub> Technological Program for the Pre-Salt - PETROBRAS

<sup>3</sup> MSc, Supervisor - Upstream Processing Technology - PETROBRAS

<sup>4</sup> PhD, General Director - ENGO ENGINEERING LTD.

<sup>5</sup> PhD, Technical Director - ENGO ENGINEERING LTD.

<sup>6</sup> PhD, Technology Director - FMC Technologies

<sup>7</sup> Engineer, Strategic Technology Manager - FMC Technologies

mol), the CO<sub>2</sub> removal module is a key part of the gas treatment facility and the performance of this part is essential for the overall system performance. From an efficiency point of view it is essential to reduce the amount of hydrocarbons lost in the CO<sub>2</sub> sent back into the reservoir (and therefore not available for direct sales).

Although the amine unit is the technology normally used for CO<sub>2</sub> removal, it would be in the limit of the technology for CO<sub>2</sub> contents above 20% mol, requiring a lot of space for the modules because the size of the plant is proportional to the amount of CO<sub>2</sub> removed (Beltrão et al., 2009). A membrane unit also occupies a significant footprint at the FPSOs, and their operation and frequent maintenance requirements are some of the most relevant areas of improvement. Even if the CO<sub>2</sub> is removed by the above mentioned available technologies, still a significant gas compressing effort is required to re-inject the CO<sub>2</sub> into the reservoir, which requires significant electrical energy needs making these technologies economically less viable.

Therefore, the concept of a new CO<sub>2</sub> separation system, which can result in future topside gas treatment plants, was investigated in this work. One example of such a compact new CO<sub>2</sub> separation technology being developed is the 3S separator technology. The principle of the 3S separator operation is based on natural gas cooling in a supersonic swirling flow. Supersonic flow is implemented using a convergent-divergent Laval nozzle. In this nozzle, the gas reaches speeds faster than the sound speed in gas. As a result, rapid cooling of gas takes place due to the conversion of flow potential energy into kinetic energy.

The supersonic technology is effective in separating and processing natural gas components. A pilot test facility in Alberta, Canada has shown that the 3S device uses 10-20% less compressor power than conventional techniques (Joule-Thomson valve or Turboexpander) for the removal of heavy hydrocarbons (Alforyov et al., 2005). The 3S separator for dewpointing is an already field proven technology and is currently being used by several operators in Russia and China.

The 3S technology has a small size (footprint), no moving parts, no routine maintenance, no chemicals, and uses the gas formation's energy, reducing the capital and operating costs compared to conventional gas processing plants. These advantages make the 3S technology specially promising for offshore applications (Alforyov et al., 2005).

The 3S device has been proven for dewpointing applications, and, with respect to a new device for the removal of CO<sub>2</sub> from natural gas, some tests under laboratory conditions will be presented in this paper. The potential for removal of CO<sub>2</sub> by means of a 3S unit has been intensively investigated during this proof of concept study. First the theoretical potentials and optimum conditions were checked by means of phase envelope analysis. The conclusion from this analysis is that a separation between methane and carbon dioxide can be achieved. And the best conditions were found to be at the lowest possible 3S nozzle temperatures, although there are some practical limitations to reach these ideal conditions.

## 2. 3S for CO<sub>2</sub> Separation Technology

The 3S (Super Sonic Separation) device is in operation for gas dewpointing (water and hydrocarbons) and under development for hydrocarbon gas/CO<sub>2</sub> separation. The separation is based on adiabatic cooling of swirling gas in a nozzle. The 3S schematic is shown in Figure 1. Figure 2 shows different view of the 3S device.

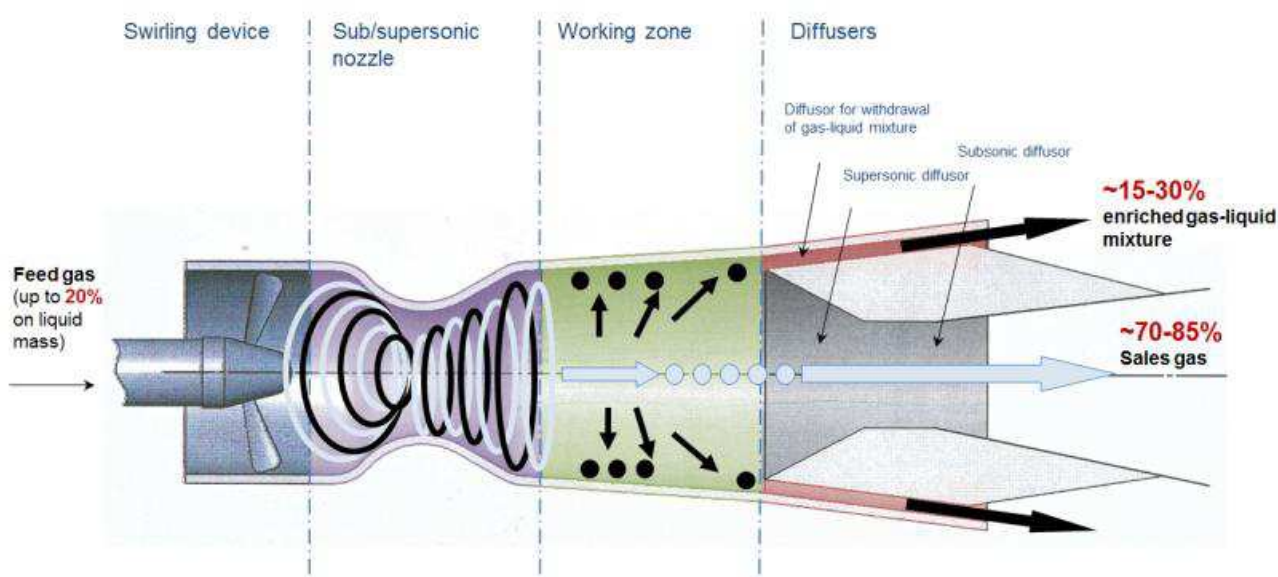

Figure 1. Schematic cross section of 3S.



Figure 2. 3S device.

Within the supersonic part of the 3S device, the swirling flow of feed stream is flashed and at these conditions split into the gas and liquid stream in accordance to the phase envelope. Centrifugal forces are used to separate droplets of condensed liquid from the gas stream. After separation, the 3S gas outlet stream flows via the working section to the diffuser and routed to the 3S gas outlet. The remainder gas is a carry-under stream combined with liquid formed and via the extraction device directed to the gas / liquid outlet.

The diffuser decelerates the stream resulting in a higher outlet pressure compared to the nozzle pressure. Consequently, the overall pressure drop across the 3S device is lower compared to a Joule Thomson valve. The 3S device is able to reach lower temperatures inside the nozzle than e.g. a Joule-Thomson valve or a turbo-expander.

The 3S for CO<sub>2</sub> removal technology is based on condensation of CO<sub>2</sub> in a hydrocarbon gas stream and separation of the condensed CO<sub>2</sub> by means of centrifugal forces. Condensation of CO<sub>2</sub> occurs in accordance to the thermodynamics of CO<sub>2</sub>-hydrocarbon phase behavior.

### 2.1. Basis of design

The basis of design as defined by Petrobras was to conduct the proof of concept study within the range of 10 to 60% mol CO<sub>2</sub> in the feed gas compositions.

Export natural gas must comply with Brazilian regulatory agency's (ANP - Agência Nacional do Petróleo, Gás Natural e Biocombustíveis) determination of maximum 3% mol CO<sub>2</sub> content. The CO<sub>2</sub> enriched stream is destined for Enhanced Oil Recovery (EOR). The product streams "export natural gas" and "CO<sub>2</sub> enriched for EOR" shall meet the specifications presented in Tables 1 and 2.

Table 1. Export gas specifications.

Specification	Value
Water Dewpoint	< - 45°C @ 1 atm
Hydrocarbon Dewpoint	< 0°C @4,5 MPa
CO <sub>2</sub> content	< 3% mol
H <sub>2</sub> S content	< 10 mg/m <sup>3</sup>

Table 2. CO<sub>2</sub> enriched stream specifications.

Specification	Value
Water content	< 1 ppmv

## 3. CO<sub>2</sub> Supersonic Separation Laboratory Tests

The tests were carried out at ENGO's Laboratory in Moscow, and simultaneously compared with mathematical simulations, seeking the phenomenon understanding and device calibration. The experimental unit has the following conditions:

- Gas capacity is 1.5 - 2.5 kg/s;
- Operation pressure is up to 75 atm (with possible increase in the future to 110-120 atm);
- Inlet temperature range from  $-70^{\circ}\text{C}$  to  $+20^{\circ}\text{C}$ .

Tests of 3S separator were carried out previously with a 3S dewpointing device, following by tests with a specific 3S device for  $\text{CO}_2$  removal. A new 3S separator with gas dynamic channel was designed and used during the laboratory tests. The scheme of the stand including the measurement systems are shown in Figure 3. The purpose of the tests were to investigate conditions at which it is possible to purify  $\text{CH}_4 + \text{CO}_2$  mixture to concentrations less than 3% mol  $\text{CO}_2$  (export gas specification). For that purpose, inlet mixture was cooled down using nitrogen.

The liquid  $\text{CO}_2$  is introduced in the experimental facilities through line 4 and is combined with  $\text{CH}_4$  in the disperser. Methane is fed from a city grid and reaches the heat exchanger in order to achieve the desired inlet temperature of the 3S separator, before proceeding to the disperser. A Mixer, upstream the 3S separator, is responsible to provide an efficient mixing of  $\text{CH}_4 + \text{CO}_2$  mixture. The 3S inlet and outlet conditions are measured as well as the pressures inside the 3S device. The outlet streams of 3S are combined and routed to the flare. A chromatograph is used to analyze the samples.

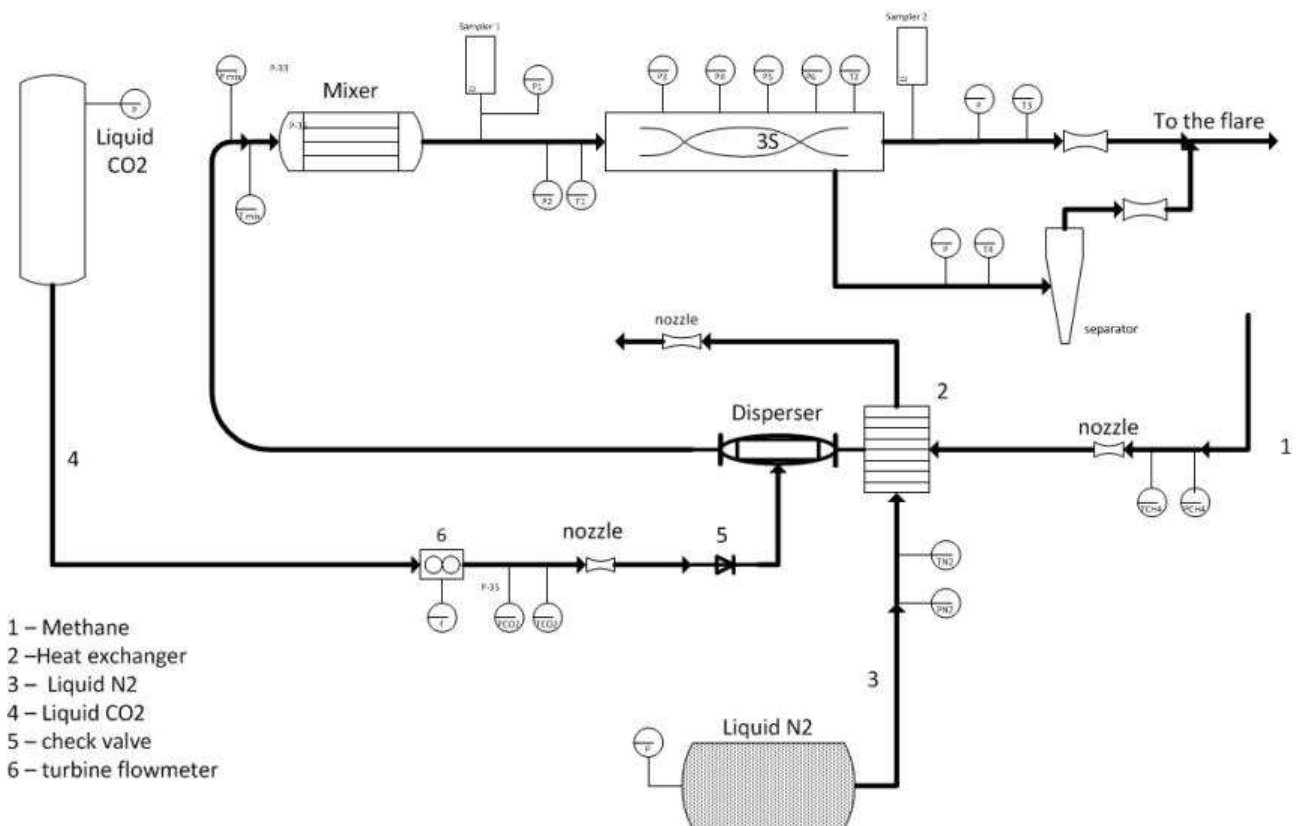
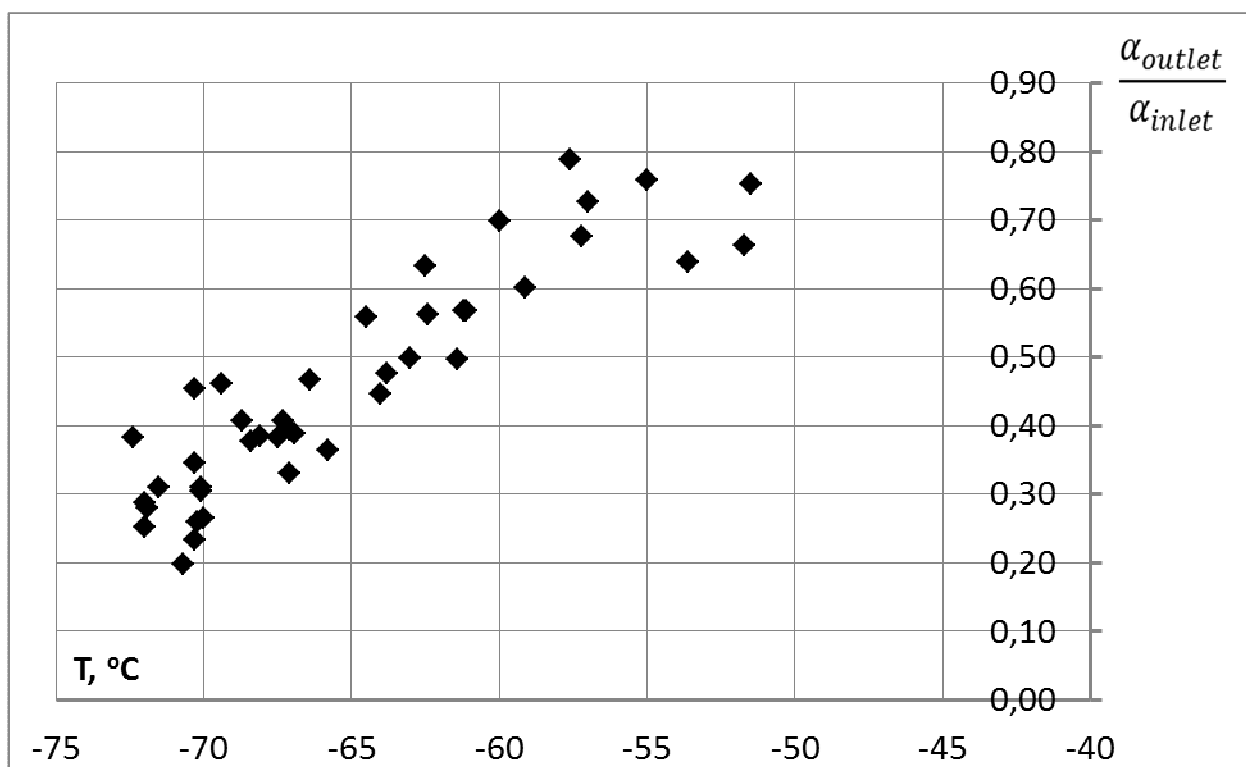

Figure 3. Experimental Test Scheme.

The main possible difficulty of the separator operating at low temperatures could be excessive overcooling of the mixture during adiabatic expansion at which the temperature of condensate droplets becomes lower than the temperature of solidification. In this case, coagulation of liquid particles would be impossible to occur and therefore the separation process could not be started up. Thus, it is necessary to organize the process in such a way that coagulation happens prior to solidification of micro-particles i.e., the process should be a thermodynamically non-equilibrium one. Also, the process should be a non-equilibrium one in boundary layer, because the formation of crystals on the walls can take place due to overcooling.

Separation of two-phase boundary layer was implemented at a rate of 18-20% from total gas mass flow rate through 3S-separator. During experiments, it has been shown that the use of a 3S-separator can provide  $\text{CO}_2$  content in treated gas below 3% mol. To ensure proper and stable operation of 3S-separator at temperatures, corresponding to  $\text{CO}_2$  crystallization, special constructive solutions have been implemented in design of 3S-separator. Reliability of measurements was confirmed by means of multiple measurements of flow conditions and gas concentrations during different tests. Some test results are shown in Figure 4.



$\alpha_{outlet}$  - concentration of CO<sub>2</sub> (mol) at the 3S outlet.  
 $\alpha_{inlet}$  - concentration of CO<sub>2</sub> (mol) at the 3S inlet.  
 T - gas temperature at the 3S inlet.

Figure 4. Diagram of test results.

As it follows from presented data, the main factor which determines high rate of mixture purifying is the temperature of the mixture. Also the following factor helps to achieve high rate of mixture purifying: due to centrifugal effect, mixture pressure in the core of the flow is 25-30% less than at the periphery, which leads to additional adiabatic cooling of mixture flow.

Obtained experimental data are used in the development of technological schemes of 3S-separation units, considering a variable CO<sub>2</sub> feed gas range, meant for CO<sub>2</sub> extraction from the gas at Pre-Salt fields.

#### 4. Conclusions

The main conclusion of this proof of concept study phase is that the 3S for CO<sub>2</sub> removal technology is a promising technology to effectively compete with conventional technologies, applied for the removal of CO<sub>2</sub> from natural gas streams.

The tests performed at ENGO's laboratory in Russia, demonstrated that it is possible to achieve 3% mol CO<sub>2</sub> at the outlet of the 3S device for CO<sub>2</sub> (or even lower concentrations). Although the preliminary tests were performed at a narrow range of CO<sub>2</sub> at the inlet of the device, the barrier of reaching the needed amount of CO<sub>2</sub> required for the export gas was overcome.

A further development of the new process schemes including the 3S for CO<sub>2</sub> device may provide deeper gains in operating parameters such as footprint and weight.

The continuity of the CO<sub>2</sub> program to perform a more detailed engineering design towards the new gas treatment plant with supersonic technology is recommended. This, in combination with the construction of a pilot skid for executing actual CO<sub>2</sub> field testing, will allow a gain of more knowledge on the capabilities of the technologies, and to identify potential optimizations and improvements that the early proof of concept phase of this study work did not cover.

By following a plan forward and jointly working in cooperation with Petrobras to better identify and understand the possibilities of proposing a more compact system design approach, it's fundamental to achieve even higher savings in comparison with the current base case adopted by Petrobras in the Pre Salt fields.

## 5. References

- ALFYOROV, V., BAGIROV, L., DMITRIEV, L., FEYGIN, V., IMAYEV, S., LACEY, J. Supersonic nozzle efficiently separates natural gas components. *Oil & Gas Journal*, p. 53-58, 2005.
- BELTRÃO, R. L. C., SOMBRA, C. L., LAGE, A. C. V. M., FAGUNDES NETTO, J. R., HENRIQUES, C. C. D. Challenges and New Technologies for the Development of the Pre-Salt Cluster, Santos Basin, Brasil. In: *Offshore Technology Conference*, Houston, Texas, USA, 2009.
- FORMIGLI FILHO, J. M., PINTO, A. C. C., ALMEIDA, A. S. Santos Basin's Pre-Salt Reservoirs Development - The Way Ahead. In: *Offshore Technology Conference*, Houston, Texas, USA, 2009.
- MIKKELSEN, R., MELO, D. C. Development of a Compact Topside Processing Facility. In: *Offshore Technology Conference Brasil*, Rio de Janeiro, Brazil, 2013.