

## Featured Articles

# Container-type Energy Storage System with Grid Stabilization Capability

Atsushi Honzawa  
Taichi Nomura  
Yuki Myogadani  
Moera Ohno  
Akihiko Emori, Dr. Eng.  
Kenji Takeda

*OVERVIEW: The installation of large amounts of renewable energy capacity, including photovoltaic and wind power generation, is anticipated. The concern with this is that connecting the fluctuating output of all this renewable energy to the grid will overwhelm its regulation capabilities, resulting in grid instability. In response, Hitachi has developed a grid stabilization system that uses a container-type energy storage system to maintain the stability of electric power use and also balance supply and demand. Hitachi aims to expand the adoption of clean energy sources by working to promote wider use of energy storage systems as one of its solutions businesses for the global market.*

## INTRODUCTION

THE installation of large amounts of renewable energy capacity, including photovoltaic and wind power generation, is seen as a means of meeting growing demand for electrical energy and of reducing carbon dioxide (CO<sub>2</sub>) emissions. Various countries have been introducing national policies such as feed-in tariffs (FITs), subsidies, and preferential tax treatments to encourage the wider adoption of renewable energy. However, because of its fluctuating output, there are concerns that connecting large amounts of renewable energy capacity to the grid will overwhelm its regulation capabilities, resulting in grid instability. To overcome this problem, Hitachi has developed a grid

stabilization system that uses a container-type energy storage system.

This article describes the background behind the development of this container-type energy storage system, which incorporates grid stabilization capabilities, along with its system configuration and features.

## HITACHI'S ENERGY STORAGE BUSINESS

Along with manufacturing materials for energy storage devices and batteries for consumer, industrial, and automotive applications, Hitachi's current activities also extend from research and development to system integration (see Fig. 1).

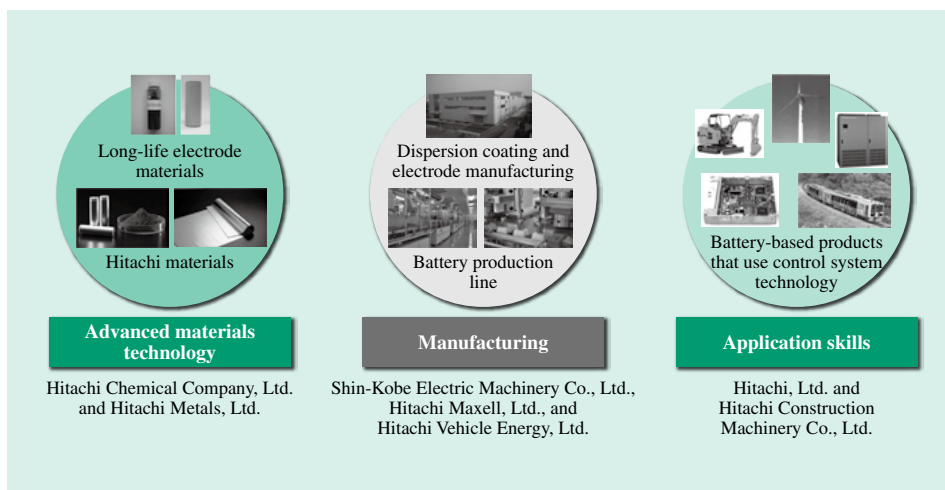

*Fig. 1—Hitachi's Battery Business.*

*Along with manufacturing materials for energy storage devices and batteries for a wide range of applications, Hitachi's activities also extend from research and development to system integration.*

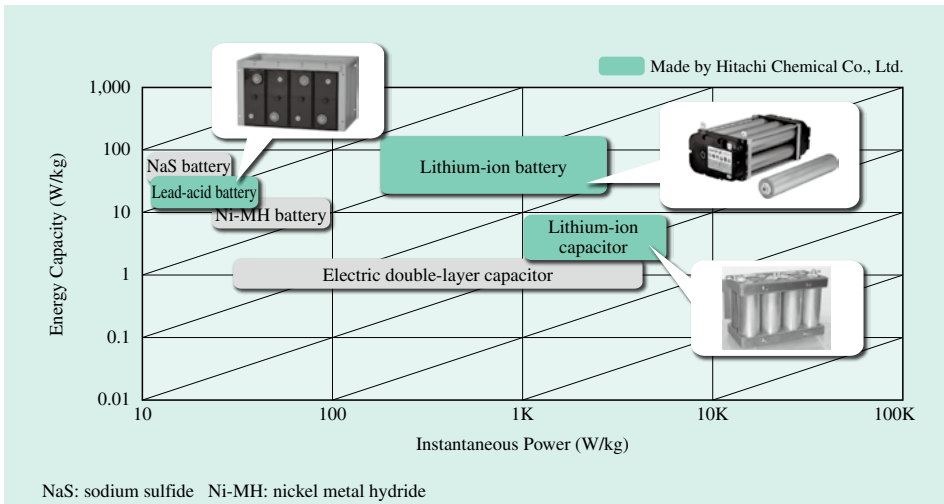

Fig. 2—Comparison of Power System and Industrial Battery Characteristics. Hitachi can configure economical systems for specific applications by selecting the best energy storage devices for the task. These include lead-acid batteries, lithium-ion batteries, and lithium-ion capacitors.

Hitachi deals with a wide range of different systems, and can configure economical systems for specific applications by selecting the best energy storage devices for the task. These include devices capable of storing comparatively large amounts of energy, such as lead-acid batteries, and devices that can deliver a high level of output over a short period, such as lithium-ion batteries (see Fig. 2).

This article describes a system for electric power grids that uses lithium-ion batteries.

### DEVELOPMENT BACKGROUND

The frequency of an electric power grid is kept stable by balancing supply and demand. As shown in Fig. 3, the connection of large amounts of renewable energy with variable output, such as photovoltaic or wind

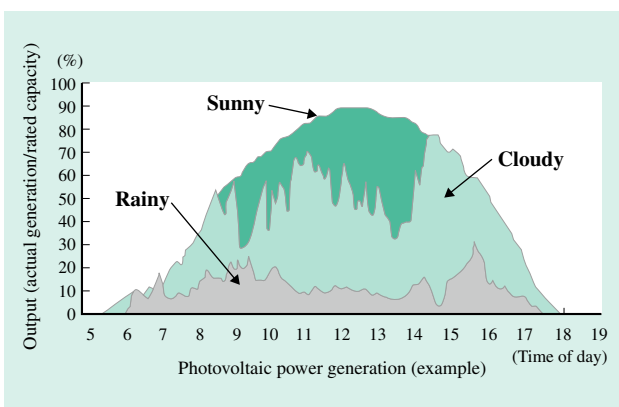

Fig. 3—Example of Weather-related Variation in Output of Photovoltaic Power Generation.

The output of a photovoltaic power plant varies widely due to the weather. In particular, large short-term variations in output occur in cloudy conditions.

power, results in a greater number of short-term power fluctuations ranging from a few seconds to ten or more minutes.

There are also off-peak times when an oversupply of generation capacity means that the amount of power generated needs to be reduced. Power fluctuations can influence the frequency of the grid, resulting in grid instability. Energy storage systems can provide an effective way of mitigating fluctuations, both in the comparatively short-term governor-free (GF) range and the load frequency control (LFC) range. Currently, control of these operating ranges is performed using the GF functions of adjustable-speed pumped storage hydro power plants and thermal power plants with high-speed control capabilities, or by the LFC function of load dispatch offices. However, because of the time needed to construct additional pumped storage hydro or thermal power plants, and because of the difficulties involved with obtaining a construction site or upgrading transmission line capacity, it is possible that upgrades to power system regulation will fail to keep up with the rapid future growth in the installation of renewable energy capacity. In comparison, an advantage of energy storage systems is that they can be installed and brought on line quickly. With few site restrictions, they can also be installed at widely distributed locations.

Although the market for grid stabilization is fragmented by the different infrastructures and structural frameworks in different countries, moves to install energy storage systems for grid stabilization have begun on a commercial scale (see Table 1). However, because energy storage systems have smaller capacities than power plants, their requirements include installation at distributed locations and centralized control from a control center.

TABLE 1. Grid Stabilization Markets in Which Energy Storage Systems can Participate

*Energy storage systems are starting to be installed for grid stabilization on a commercial scale.*

Item	Electric power/grid stabilization market		
Market type	Europe and USA (where electricity market deregulation has taken place)	Japan (led by power companies)	Emerging economies Countries with low energy density (weak transmission infrastructure)
Mechanism	Ancillary service		Microgrids incorporating wind and photovoltaic power
	ISOs purchase regulation capacity from market	Power companies use set-aside capacity	Trend is toward generators being required by grid code to also install wind or photovoltaic power
Size of battery system	1-MW increments (approx.)	Centralized systems with capacities in the tens of MW	Additional installation of 1 to 20 MW

ISO: independent system operators, Ancillary service: a service whereby the grid operator maintains grid stability by using spare capacity or other adjustment methods to respond to variations in the level of power that a generator supplies to the grid, grid code: rules for transmission grid operation

The USA has already introduced a market for frequency regulation (FR) in which independent system operators (ISOs) and regional transmission organizations (RTOs) can provide ancillary services for reducing power fluctuations by purchasing (by MW and by hour) electric power to mitigate short-term fluctuations ranging from several seconds to several tens of minutes. The ISOs minimize fluctuations in grid frequency by issuing instructions at intervals of several seconds to the purchased power source. The value of transactions on the fast response market is particularly high. This market operates in such a way

that responding accurately to instructions is valued more highly. Because the FR market requires batteries to charge and discharge repeatedly over short periods with comparatively high currents, it suits lithium-ion batteries, which can handle heavy currents and have high charging and discharging efficiency.

PJM Interconnection (PJM), a major RTO based in the eastern USA, is a notable participant in the FR market. This is a result of its being one of the first organizations to start operating systems in accordance with Federal Energy Regulatory Commission (FERC) Order 755 of October 1, 2012, which requires that a premium be paid for the supply of power from energy storage systems, such as batteries, which can respond accurately to ISO instructions, over power from thermal and other conventional generators.

Other than the region represented by PJM, another major region in the USA with impressive hopes for renewable energy is California, which has set a target of raising the proportion of electric power supplied from renewable energy to 33% by 2020. To achieve this, California passed assembly bill AB2514 in 2010 that requires the installation of energy storage systems on the grid. In accordance with AB2514, the California Public Utilities Commission (CPUC) in October 2013 instructed the state’s three main utilities, Southern California Edison (SCE), Pacific Gas and Electric (PG&E), and San Diego Gas & Electric (SDG&E), to install a total energy storage system capacity of 1.3 GW by 2020.

A 1-MW container-type energy storage system fitted with lithium-ion batteries was developed to target these markets in particular. The system is installed at

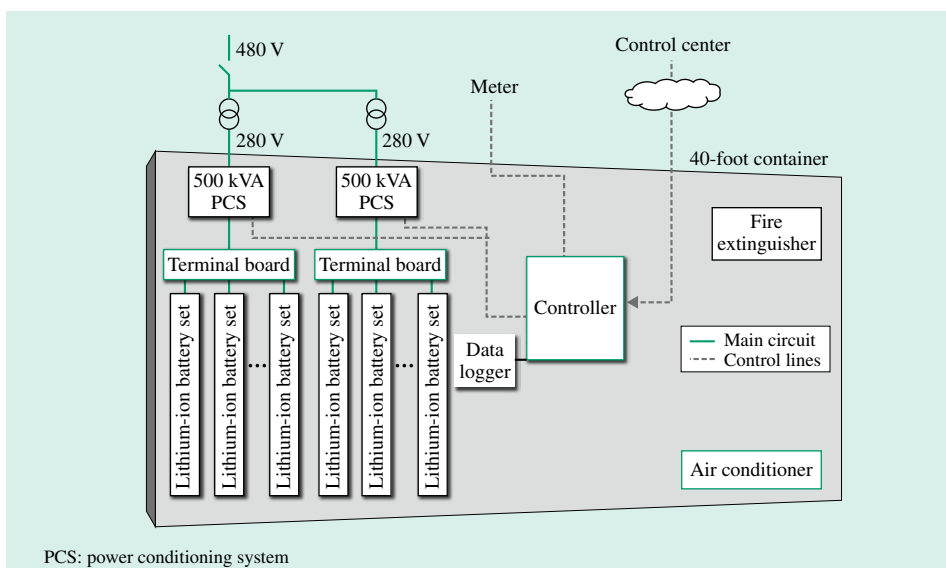

Fig. 4—Block Diagram of 1-MW Container Package. The 1-MW container-type energy storage system includes PCSs, lithium-ion battery sets, a controller, a data logger, and air conditioner.

factories or other sites with the capacity to consume comparatively high levels of electric power, or at sites such as photovoltaic power plants, wind farms, or substations. In Japan, meanwhile, full-scale trials of the use of energy storage systems for grid stabilization have already commenced, primarily on offshore islands or in regions with poor transmission infrastructure, and Hitachi is looking at the potential for using this system.

### DEVELOPMENT CONCEPT FOR 1-MW CONTAINER-TYPE ENERGY STORAGE SYSTEM

The 1-MW container-type energy storage system includes two 500-kW power conditioning systems (PCSs) in parallel, lithium-ion battery sets with capacity equivalent to 450 kWh, a controller, a data logger, air conditioning, and an optional automatic fire extinguisher. Fig. 4 shows a block diagram.

Hitachi designed the 1-MW container-type energy storage system to incorporate all of the components, including the PCSs, batteries, and controller, into a 40-foot container as an all-in-one package. This minimizes the installation work, significantly reducing the time and cost of installation. Furthermore, along with a single-container system configuration, the package was also designed to facilitate the configuration of large-capacity systems made up of multiple containers. Table 2 lists the specifications and Fig. 5 shows a photograph.

### FEATURES OF 1-MW CONTAINER-TYPE ENERGY STORAGE SYSTEM

The features of the system are as follows:

(1) Improved availability

To improve availability, it is necessary not only to make maintenance inspections shorter and reduce failure rates, but also to shorten the duration of service outages needed to maintain battery conditions, including the performance of battery-specific cell voltage equalization, and the use of resets to determine the state of charge (SOC) (whereby charging and discharging of a battery is halted for a fixed time to determine its SOC). When SOC is measured by integrating the battery current over time, it is necessary to perform reset charging frequently in order to eliminate the cumulative measurement error that occurs in FR applications due to the high frequency of battery charging and discharging. In the case of the lithium-ion battery modules used in the container-

TABLE 2. Specifications of 1-MW Container Package  
A 40-foot container houses 1 MW/450 kWh of batteries, a PCS, controller, and other equipment.

Item	Specification	Remarks
System capacity	±1 MW	System level
PCSs	2 × 500 kW in parallel	
PCS efficiency	97% or higher (at 30% or higher load)	
Batteries	Lithium-ion 450 kWh	Battery modules: CH75-6 (75Ah-22.2V)
Standard	PCS: UL 1741	
Expected life	System: 15 years or more Batteries: 10 years or more	When installed in an approved environment and maintained correctly
Cooling	Air cooled	
Container	40-foot class	

type energy storage system, however, reset charging is not required because the battery management unit (BMU) uses continuous battery voltage and current measurements to calculate a realtime estimate of SOC. This has significantly improved availability. Also, cell voltage equalization is performed continuously by the built-in cell controller.

(2) Longer battery life and improved reliability

Because of the high cost of existing lithium-ion batteries, it is essential that batteries have a long and reliable operating life in order to earn a return on investment. The CH75 lithium-ion batteries used in the container-type energy storage system have a circularly wound design with a long life and high capacity (75 Ah). These batteries can be charged or discharged at three times capacity (3C: 75 A × 3) and have a life of 8,000 cycles or more when used with a 1C charge/discharge rate. When designing the module layout and air flow, Hitachi also conducted temperature analyses



Fig. 5—1-MW Container Package.  
The photograph shows the 1-MW container package.

of the battery set to ensure that all battery modules receive roughly equivalent cooling. The batteries have a predicted life of about 10 years under the anticipated operating conditions.

The use of high-capacity battery cells not only significantly reduces the number of batteries to be connected together, it also improves reliability by reducing the component count for auxiliary functions such as the BMU and battery controller unit (BCU). A large fan has been fitted to provide centralized cooling. Because fans require maintenance and periodic replacement, this improves reliability and reduces the replacement costs because the number of fans is much smaller than if separate fans were provided for each module.

#### (3) Improved system efficiency

Because the electrical losses in charging and discharging contribute to operating costs, improvements to system efficiency are reflected in higher income from FR services. Improving system efficiency requires not only more efficient charging and discharging of the lithium-ion batteries, it also requires improvements to PCS efficiency and a reduction in losses due to the cooling system. FR instructions vary randomly and at short intervals, and the system frequently operates at the lower end of its rated output capacity. The PCSs used in the container-type energy storage system have a conversion efficiency of 97% or higher at low load, with a high system-level charging and discharging efficiency of about 90% being achievable in practice.

#### (4) Compliance with standards

To satisfy the requirements of the US market, the PCS has been certified under the UL 1741 safety standard for distributed energy resources.

#### (5) Safety

If used incorrectly, lithium-ion batteries are a fire risk. The safety of the individual lithium-ion batteries used in the container-type energy storage system has been enhanced by the use of an electrode design that minimizes the risk of internal short circuits, and by packaging them in stainless steel for better durability. Multiple safety features are also provided at the system level, including the monitoring of voltage, current, temperature, and other battery parameters by the BMU and BCU so that a battery set can be disconnected if an abnormality is detected, and the provision of circuit breakers in both the direct current (DC) and alternating current (AC) circuits of the PCSs. Also available as an option is a fire control system that can detect smoke and extinguish a fire in the event of fire or smoke inside the container.

## FUTURE DEVELOPMENTS

The newly developed container-type energy storage system is scheduled to enter service in the US FR market during FY2014. Hitachi intends to analyze operational data with the aim of further extending the system life and making it more compact. Hitachi also intends to incorporate lead-acid batteries into the system to expand its applications, including its use as a countermeasure against oversupply of renewable energy, and as a peak shifting system for minimizing peak demand. Achieving wider use of energy storage systems will require more than just improvements in cost-performance and lower battery prices. Longer battery life and higher system efficiency will also be important factors in enhancing performance.

## CONCLUSIONS

By drawing on capabilities from across the group, Hitachi believes that use of clean energy can be expanded and CO<sub>2</sub> emissions reduced by the development of energy storage devices and systems that overcome a variety of challenges, and by promoting the wider adoption of these systems.

## REFERENCES

- (1) T. Shibata, K. Sudo and Y. Kanazawa, "Energy Storage Solutions Utilizing Lithium-ion Batteries," *Hitachi Review* **60**, pp.12–16 (2011).
- (2) M. Toyota et al., "Energy Storage Technology and Batteries Required for Hitachi's Vision for a Smart Society – Latest Materials Technology and Performance Evaluation of Next-generation Batteries," Technical Information Institute Co., Ltd., p.802–807 (Dec. 2013) in Japanese.

## ABOUT THE AUTHORS

---



**Atsushi Honzawa**

*Power System Information & Controls Department, Power Systems Company, Hitachi, Ltd. He is currently engaged in commercializing power system stability solutions, especially energy storage systems. Mr. Honzawa is a Project Management Professional (PMP) and Convenor of IEC TC120 WG2 (Electrical Energy Storage System, Unit Parameters and Testing Methods).*



**Taichi Nomura**

*Energy Business Development & Management Center, Infrastructure Systems Company, Hitachi, Ltd. He is currently engaged in commercializing energy solutions centered on energy storage systems.*



**Yuki Myogadani**

*Power System Protection Automation & Solution Center; Energy Systems Engineering Department, Hitachi, Ltd. He is currently engaged in work on designing and developing energy storage systems.*



**Moera Ohno**

*Industrial and Infrastructure Systems Division, Hitachi America, Ltd. He is currently engaged in promoting the power system stability solutions, especially the energy storage systems.*



**Akihiko Emori, Dr. Eng.**

*System Development Department, Energy Devices & System Development Center, Hitachi Chemical Company, Ltd. He is currently engaged in designing and developing energy storage systems. Dr. Emori is a member of The Institute of Electrical Engineers of Japan (IEEJ).*



**Kenji Takeda**

*Battery Research Department, Hitachi Research Laboratory, Hitachi, Ltd. He is currently engaged in researching and developing power systems utilizing power converters and various batteries.*